

2712 Flanged

2/2-way Globe Control Valve, flange connection, 1/2" - 4"



Complete Burkert system using Type 2712 with TopControl 8630

- New generation with interchangeable trims, 3 to 5 Cvs-value per connection port
- Excellent control characteristic
- Ultra compact design
- Standard International Face-to-face dimensions

Type 2712 can be combined with...

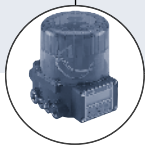

Type 8630

Positioner or process controller

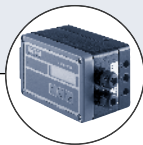

Type 1067

Controller SideControl

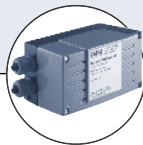

Type 8635

Controller SideControl

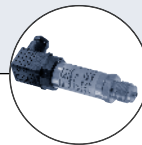

Type 8323

Pressure transmitter

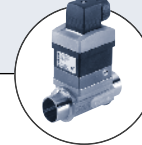

Type 8030

Flow sensor

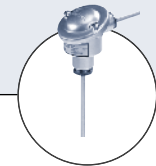

Type ST20

Temperature sensor

The 2712 system has been specifically engineered for reliable control in applications where control accuracy is paramount.

The 2712 is made from an all stainless steel valve body combined with Burkert's new generation universal pneumatic actuator.

Each globe valve body can be fitted with three to five sizes of trim sets. These parabolic trims provide a reliable and repeatable characteristic to vary the flow. The control cones are available in either stainless steel or with a durable PTFE seal for tight shut-off.

When actuated by the 1067/8635 SideControls or the 8630 TopControl it forms a unique control valve system which can be operated as either a simple accurate positioner or an autotune PID process controller for flow, temperature or pressure.

Proven Applications

- Fine chemical pressure and flow control
- High accuracy test bench equipment
- Food, beverage and pharmaceutical CIP/SIP and auxiliary processes with steam
- Pharmaceutical Sterilizers
- Precision distillation apparatus
- Sterile Packaging Machinery

Technical data	
Materials	
Body	Cast stainless steel 316L (conform to 1.4409)
Actuator	PA (polyamide) (PPS on request)
Plug sealing	SS/SS (stainless steel/stainless steel) PTFE/SS
Seat leakage acc. IEC 534-4/EN 1349	Shut-off class IV for SS/SS Shut-off class VI for PTFE/SS (266 °F Max.)
Process media gases and liquids (vacuum version on request)	For neutral gases, water, alcohols, oils, fuels, hydraulic liquids, salt solutions, lyes, organic solvents, steam, 150 PSI / 365°F (10.3 bar /185°C)
Viscosity	Max. 600 mm ² /s; 600 cSt; .93 in ² /s
Packing gland	PTFE V-rings (silicone grease) with spring compensation
Nominal pressure	PN 25 (body)
Temperatures	
Fluid	14°F to 365°F (-10°C to +185°C) ¹⁾ (266°F for PTFE/SS sealing recommended)
Ambient	14°F to 140°F (-10°C to +60°C) ¹⁾ Actuators F-80 to H-125 14°F to 122°F (-10°C to +50°C) Actuators K-175 and L-225
Control media	Compressed air (40 micron filter)
Pilot pressure	79.75 to 101.5 PSI (5.5 to 7 bar) Actuators F-80 to H-125 72.5 to 87 PSI (5 to 6 bar) Actuators K-175 and L-225
Pilot air ports	G 1/4 stainless steel (SS)
Flow direction	Below seat
Mounting position	Any, preferably upright
Interchangeable seat	Different Cvs-values per port size, see table p.4
Control ratio (Cvs/Cv0)	50:1 25:1 for orifice DN6 10:1 for orifice DN4
Port connections	
Flange	
ANSI	ANSI B16.5 RF ²⁾ Class 150 face-to-face EN 558-2 (ISA S75.03)

¹⁾ high temperature version on request

²⁾ Raised face (RF)

Globe Valve Systems

A continuous globe valve system consists of a continuous globe valve Type 2712 and a valve actuation system SideControl Type 1067 or Type 8635 or TopControl Type 8630. The positioners are only delivered in combination with an actuator as a part of a complete control valve. The following information is necessary for the selection of a complete Globe Valve System:

- **Item no.** of the continuous globe valve Type 2712 (see Ordering chart)
- **Item no.** of the desired positioner Type 8630, 1067 or 8635 (see separate datasheets)

Example for variations of continuous Globe Valve Systems

DTS 1000082425 EN Version: D Status: RL (released | freigegeben | validé) printed: 20.01.2015

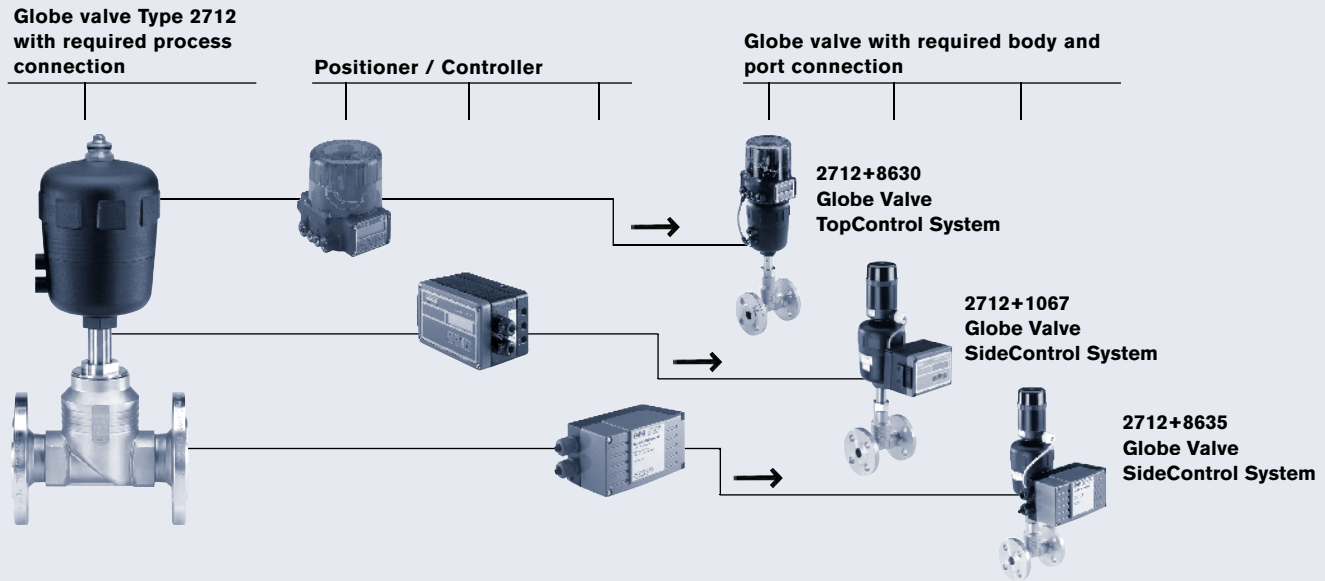

Valve actuation system: TopControl

TopControl Continuous Type 8630 forms a mechanical and functional unit with the pneumatic actuator. The main parts of the TopControl Continuous are:

- Positioner and/or process controller in one device, integrated PID (as option)
- Linear potentiometer connects to stem with zero backlash for precise position control.

- Microprocessor controlled electronics for signal processing, setpoint/process value comparison
- Pneumatic positioning system for single and double-acting actuators with integrated pilot valves
- New process tune function reduces time and costs during PID parameter set up.

Type: 8630



0/4...20 mA
0...5/10 V



DeviceNet™

Valve actuation system: SideControl 3-wire

SideControl Type 1067 is a 3-wire process controller and positioner composed of the main functional groups position measuring system, electropneumatic actuator system and microprocessor electronics. Main functional groups of the SideControl are:

- Positioner and process controller in one device, integrated PID
- Linear potentiometer connects to stem with zero backlash for precise position control.

- Microprocessor controlled electronics for signal processing, setpoint/process value comparison
- Pneumatic positioning system for single and double-acting actuators with integrated pilot valves
- Remote versions available for distances up to 330 ft between valve and positioner
- The software function autotune implemented enables automatic adaptation of the positioner to the control valve used.

Type: 1067



0/4...20 mA
0...5/10 V

Valve actuation system: SideControl 2-wire, intrinsically safe

SideControl Type 8635 is a 2-wire electropneumatic process controller and positioner for pneumatically operated process valves. As an alternative, communication can be effected via HART or PROFIBUS PA.

- Signal processing, control and drive of the internal positioning system are carried out by microprocessor controlled electronics
- The software function autotune implemented enables automatic adaptation of the positioner to the control valve used
- Parametrization and operation are performed comfortably via three keys and a display with plain text, or via HART and PROFIBUS PA

- To build up a decentralized control system, SideControl is equipped with a process controller with PID behaviour. In this case, a process control loop is superimposed on the positioning loop in a cascade structure
- The compact, robust design, the housing is suitable for use in chemical and process-engineering
- New process tune function reduces time and costs during PID parameter set up.

Type: 8635



0/4...20 mA
0...5/10 V



Technical data

Cvs values

Port size (connection)	Actuator size	Orifice DN (seat) [mm]												
		04	06	08	10	15	20	25	32	40	50	65	80	100
15	F-80	0.58	1.39	2.4	3.6	5.0	-	-	-	-	-	-	-	-
20	F-80	-	-	-	3.7	6.0	8.2	-	-	-	-	-	-	-
25	F-80	-	-	-	-	6.1	8.4	13.9	-	-	-	-	-	-
40	G-100	-	-	-	-	-	-	15.8	23.4	27.6	-	-	-	-
50	H-125	-	-	-	-	-	-	-	24.4	28.5	42.9	-	-	-
65	H-125	-	-	-	-	-	-	-	-	20.3	30.2	60.3	-	-
65	K-175	-	-	-	-	-	-	-	-	29.6	45.8	71.9	-	-
80	L-225	-	-	-	-	-	-	-	-	-	48.7	81.2	116	-
100	L-225	-	-	-	-	-	-	-	-	-	-	87.0	133	162

Flow curve and description

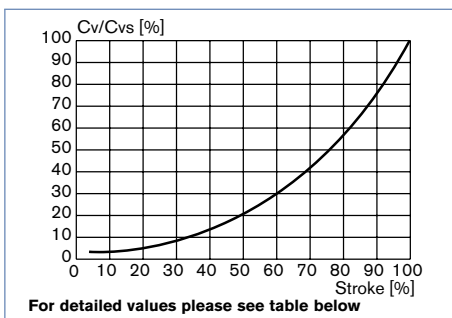

Remarks on the flow characteristic

- Equal percent parabolic plug for the orifices DN8...DN100
- Linear plug for the orifices DN4 and DN6
- Flow characteristic runs within DIN/IEC 534-2-4
- Theoretical control ratio (Cvs/Cvo):
 - 50:1 for the orifices DN8...DN100
 - 25:1 for the orifice DN6
 - 10:1 for the orifice DN4
- CVR value at 5% of stroke for DN > 10 mm
CVR value at 10% of stroke for DN ≤ 10 mm
(CVR value = smallest Cv value at which the gradient tolerance to DIN/IEC 534-2-4 is still complied with)

Cv values

Port size (connection)	Orifice (seat)	Actuator	Stroke [%]												
			5	10	20	30	40	50	60	70	80	90	100		
15	4 1/8"	F-80	0.05	0.06	0.12	0.19	0.26	0.31	0.37	0.42	0.46	0.51	0.58		
		F-80	0.06	0.14	0.37	0.56	0.72	0.88	1.02	1.14	1.24	1.31	1.39		
		F-80	0.08	0.09	0.13	0.15	0.22	0.31	0.50	0.73	1.10	1.86	2.40		
		F-80	0.10	0.13	0.17	0.22	0.36	0.57	0.87	1.28	1.97	2.90	3.60		
		F-80	0.16	0.20	0.26	0.41	0.60	0.93	1.39	2.10	3.10	4.30	5.00		
20	3/4"	F-80	0.13	0.14	0.19	0.23	0.38	0.60	0.89	1.39	2.10	3.00	3.70		
		F-80	0.16	0.20	0.26	0.41	0.60	0.93	1.39	2.10	3.40	4.60	6.00		
		F-80	0.23	0.29	0.35	0.52	0.81	1.28	1.86	2.80	4.10	6.00	8.20		
25	1"	F-80	0.16	0.20	0.26	0.41	0.60	0.93	1.39	2.10	3.40	4.80	6.10		
		F-80	0.23	0.29	0.36	0.55	0.81	1.28	1.86	2.90	4.40	6.30	8.40		
		F-80	0.41	0.44	0.75	1.16	1.74	2.60	3.90	5.90	8.10	10.9	13.9		
40	1 1/2"	G-100	0.46	0.58	0.87	1.28	1.97	3.00	4.40	6.50	9.30	12.4	15.8		
		G-100	0.56	0.70	0.99	1.51	2.40	3.70	5.30	8.00	12.8	17.4	23.4		
		G-100	0.70	0.81	1.28	1.97	3.10	4.60	7.00	10.7	16.0	21.1	27.6		
50	2"	H-125	0.56	0.70	1.04	1.51	2.40	3.70	5.30	8.00	13.5	18.6	24.4		
		H-125	0.70	0.81	1.16	1.97	3.00	4.60	6.80	10.7	16.2	21.9	28.5		
		H-125	1.04	1.28	2.20	3.40	5.20	7.90	12.2	18.0	25.5	34.0	42.9		
65	2 1/2"	H-125	0.52	0.75	1.10	1.51	2.20	3.20	4.60	6.40	9.00	13.6	20.3		
		H-125	0.81	1.16	1.86	2.80	4.10	5.70	8.00	11.4	16.4	23.1	30.2		
		H-125	0.93	1.51	2.40	3.70	6.40	10.6	17.1	28.4	43.6	52.9	60.3		
		K-175	0.52	0.64	0.99	1.51	2.30	3.60	5.30	7.90	12.4	20.0	29.6		
		K-175	0.87	1.04	1.74	2.70	4.10	5.70	8.20	12.8	20.3	30.2	45.8		
		K-175	1.28	1.62	2.40	3.70	5.70	9.30	13.9	21.5	36.5	53.9	71.9		
80	3"	L-225	0.99	1.16	1.74	2.70	4.10	5.80	8.20	12.2	18.6	29.0	48.7		
		L-225	1.62	1.97	2.90	4.40	6.60	9.50	14.2	22.6	37.7	58.0	81.2		
		L-225	2.40	3.00	4.90	8.10	12.2	18.6	29.0	46.4	69.6	96.3	116		
100	4"	L-225	1.62	1.97	3.00	4.40	6.60	9.60	14.6	23.2	37.1	59.2	87.0		
		L-225	2.40	3.00	5.00	8.10	12.8	19.7	30.7	51.0	75.4	103	133		
		L-225	3.70	4.50	6.60	10.4	15.7	23.8	37.1	59.2	96.3	137	162		

DTS 1000082425 EN Version: D Status: RL (released | freigegeben | valide) printed: 20.01.2015

Materials

1/2" – 2 1/2" (actuator sizes F–80 to H–125 mm)

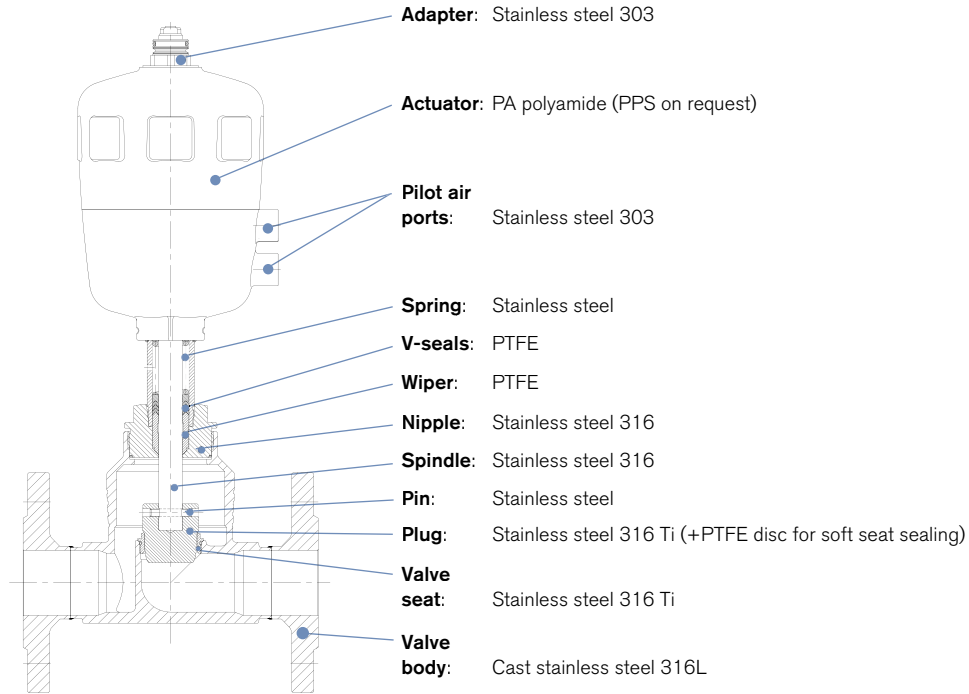

2 1/2" – 4" (actuator sizes K–175 and L–225 mm)

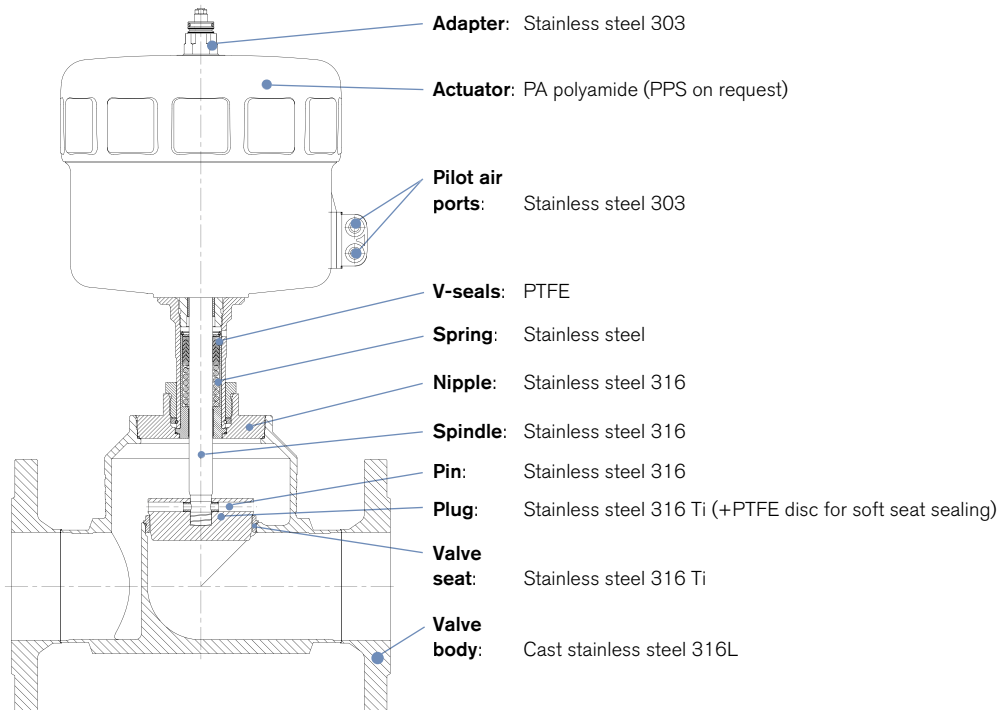

Ordering chart: Globe Valve System

Flange: ANSI B16.5 Class 150, face-to-face EN 558-2 (ISA S75.03), flow below seat

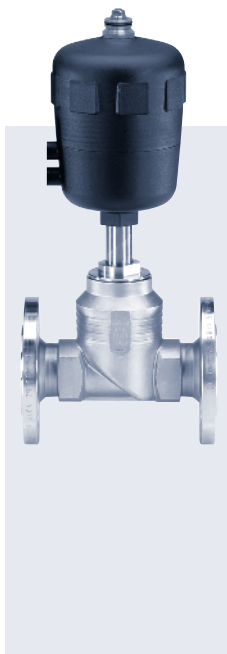

Control function	Port size (tube)		Orifice DN (seat)		Actuator size Ø [mm]	Op. pressure ≤ +365 °F [PSI]	Item no. seal system SS/SS*	Item no. seal system PTFE/SS*
	[mm]	[inch]	[mm]	[inch]				
A 2/2-way, NC by spring return	15	1/2"	4	1/8"	F-80	232	461 491	-
			6	3/16"	F-80	232	461 492	-
			8	1/4"	F-80	232	146 680	146 966
			10	3/8"	F-80	232	146 702	146 990
			15	1/2"	F-80	232	146 730	147 018
	20	3/4"	10	3/8"	F-80	232	146 716	147 004
			15	1/2"	F-80	232	146 744	147 032
			20	3/4"	F-80	232	146 772	147 060
	25	1"	15	1/2"	F-80	232	146 758	147 046
			20	3/4"	F-80	232	146 786	147 074
			25	1"	F-80	232	146 812	147 100
	40	1 1/2"	25	1"	G-100	232	146 836	147 126
			32	1 1/4"	G-100	232	146 862	147 152
			40	1 1/2"	G-100	232	146 890	147 179
	50	2"	32	1 1/4"	H-125	232	146 876	147 165
			40	1 1/2"	H-125	232	146 904	147 196
			50	2"	H-125	232	146 918	147 210
	65	2 1/2"	40	1 1/2"	H-125	232	155 743	155 964
			50	2"	H-125	232	155 782	156 001
			65	2 1/2"	H-125	232	155 838	156 063
40			1 1/2"	K-175	232	155 763	155 984	
50			2"	K-175	232	155 801	156 021	
80	3"	65	2 1/2"	K-175	232	155 859	156 084	
		50	2"	L-225	232	155 821	156 038	
		65	2 1/2"	L-225	232	155 878	156 100	
100	4"	80	3"	L-225	232	154 642	156 133	
		80	3"	L-225	232	155 930	156 149	
		100	4"	L-225	232	154 643	156 166	
B 2/2-way, NO by spring return	15	1/2"	4	1/8"	F-80	232	461 493	-
			6	3/16"	F-80	232	461 494	-
			8	1/4"	F-80	232	146 684	146 972
			10	3/8"	F-80	232	146 709	146 997
			15	1/2"	F-80	232	146 737	147 025
	20	3/4"	10	3/8"	F-80	232	146 723	147 011
			15	1/2"	F-80	232	146 751	147 039
			20	3/4"	F-80	232	146 779	147 067
	25	1"	15	1/2"	F-80	232	146 765	147 053
			20	3/4"	F-80	232	146 793	147 081
			25	1"	F-80	232	146 817	147 107
	40	1 1/2"	25	1"	G-100	232	146 843	147 133
			32	1 1/4"	G-100	232	146 869	147 158
			40	1 1/2"	G-100	232	146 897	147 189
	50	2"	32	1 1/4"	H-125	232	146 833	147 172
			40	1 1/2"	H-125	232	146 911	147 203
			50	2"	H-125	232	146 923	147 217
	65	2 1/2"	40	1 1/2"	H-125	232	155 753	155 974
			50	2"	H-125	232	155 791	156 011
			65	2 1/2"	H-125	232	155 848	156 073
			40	1 1/2"	K-175	232	155 772	155 992
			50	2"	K-175	232	155 811	156 029
	80	3"	65	2 1/2"	K-175	232	155 869	156 091
			50	2"	K-175	232	155 830	156 045
			65	2 1/2"	K-175	232	155 887	156 107
	100	4"	80	3"	K-175	232	155 922	156 141
			65	2 1/2"	K-175	232	155 905	156 123
			80	3"	K-175	232	155 939	156 157
			100	4"	K-175	232	155 955	156 174

*seal system:
 • SS/SS: plug stainless steel/
 seat stainless steel
 • PTFE/SS: plug PTFE/
 seat stainless steel

Dimensions

DN 13–65 (1/2" – 2 1/2")

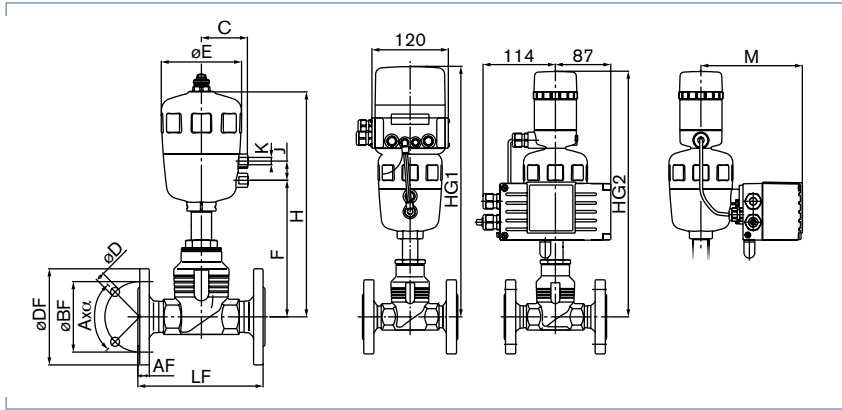

Angles α_{α}	
Port size [mm]	ANSI flange
10	4x90°
15	4x90°
20	4x90°
25	4x90°
32	4x90°
40	4x90°
50	4x90°
65	4x90°

Port size [mm]	8630		1067		8635	
	HG1	HG2	M	HG2	M	
10	391	384	145	384	159	
15	391	384	145	384	159	
20	386	379	145	379	159	
25	389	382	145	382	159	
32	476	469	158	469	172	
40	481	474	158	474	172	
50	518	511	171	511	185	
65	547	511	171	511	185	

Port size [mm]	Actuator size	Weight [kg] ¹⁾	ANSI flange											
			C	E	F	H	K	J	DF	LF	ØBF	AF	D	
10	F-80	5	60	101	166	264	G 1/4	24	-	-	-	-	-	-
15	F-80	5	60	101	166	264	G 1/4	24	89.0	184	60.5	11.2	15.7	-
20	F-80	6	60	101	160	259	G 1/4	24	99.0	184	69.9	12.7	15.7	-
25	F-80	7	60	101	164	262	G 1/4	24	108.0	184	79.2	14.2	15.7	-
32	G-100	11	73	127	208	346	G 1/4	30	-	-	-	-	-	-
40	G-100	12	73	127	214	351	G 1/4	30	127.0	222	98.6	17.5	15.7	-
50	H-125	17	86	157	225	388	G 1/4	30	152.0	254	120.7	19.1	19.1	-
65	H-125	21	86	157	254	417	G 1/4	30	178.0	276	139.7	22.3	19.1	-

¹⁾ Approximately weight with positioner

DN 65–100 (2 1/2" – 4")

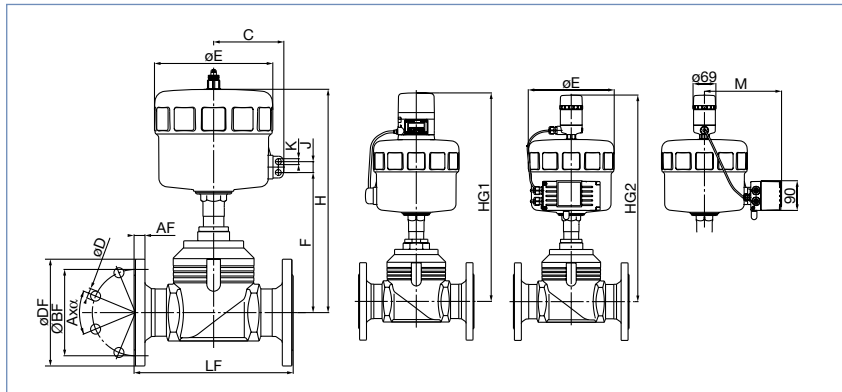

Angles α_{α}	
Port size [mm]	ANSI flange
65	4x90°
80	4x90°
100	8x45°

Port size [mm]	8630		1067		8635	
	HG1	HG2	M	HG2	M	
65	621	613	220	613	209	
80	624	617	220	617	234	
100	634	626	195	626	234	

Port size [mm]	Actuator size	Weight [kg] ¹⁾	ANSI flange											
			C	E	F	H	K	J	DF	LF	ØBF	AF	D	
65	K-175	28	130	211	289	479	G 1/4	24	178	276	139.7	22.3	19.1	-
80	L-225	38	155	261	299	482	G 1/4	24	190	298	152.4	23.9	19.1	-
100	L-225	46	155	261	309	492	G 1/4	24	29.0	352	190.5	23.9	19.1	-

¹⁾ Approximately weight with positioner

DTS 1000082425 EN Version: D Status: RL (released | freigegeben | valide) printed: 20.01.2015

Further process connections

Threaded ends



- G
- NPT
- RC

Weld ends

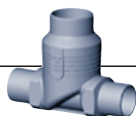

- ISO 4200
- DIN 11850 S2
- BS 4825
- ASME BPE
- SMS 3008

Tri-Clamp®

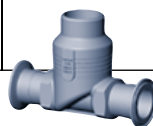

- ISO 2852
- SMS 3017
- DIN 32676
- BS 4825

Customized*



*e.g. one side with flange,
other side Tri-Clamp®

Spare parts for Type 2712 – DN 10–100 (on request)

Port size 10 to 65 in combination with actuator size F–80 to H–125

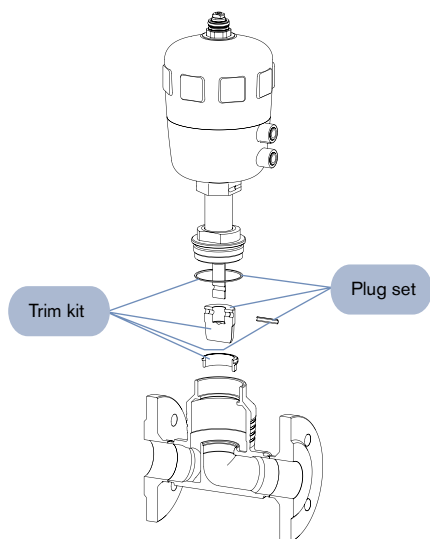

Port size 65 to 100 in combination with actuator size K–175 and L–225

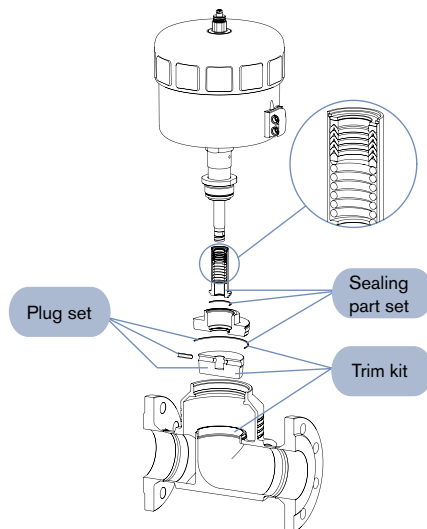

Specification sheet for control valves: Please fill out and send to your local Burkert Sales Center* with your inquiry or order

DTS 1000082425 EN Version: D Status: RL (released | freigegeben | valide) printed: 20.01.2015

<input type="checkbox"/> = mandatory fields to fill out		Quantity	Required delivery date
Operating data			
Site of control	<input type="text"/>		
Measuring and control task	<input type="text"/>		
Pipeline	DN <input type="text"/>	PN <input type="text"/>	
Pipe material	<input type="text"/>		
<input type="checkbox"/> Process medium	<input type="text"/>		
<input type="checkbox"/> Type of media	<input type="checkbox"/> Liquid	<input type="checkbox"/> Steam	<input type="checkbox"/> Gas
	Min	Standard	Max
<input type="checkbox"/> Flow rate (Q, Q _N , W) ¹⁾	<input type="text"/>	<input type="text"/>	<input type="text"/>
<input type="checkbox"/> Temperature at valve inlet T1	<input type="text"/>	<input type="text"/>	<input type="text"/>
<input type="checkbox"/> Absolute pressure at valve inlet P1	<input type="text"/>	<input type="text"/>	<input type="text"/>
<input type="checkbox"/> Absolute pressure at valve outlet P2	<input type="text"/>	<input type="text"/>	<input type="text"/>
<input type="checkbox"/> Steam pressure P _v	<input type="text"/>	<input type="text"/>	<input type="text"/>
<input type="checkbox"/> Kinematic viscosity (ν)	<input type="text"/>	mm ² /s or cSt	
<input type="checkbox"/> Dynamic viscosity (η)	<input type="text"/>	mPa.s or cP	
<input type="checkbox"/> Standard density	<input type="text"/>	Kg/m ³	
<input type="checkbox"/> Max. sound level accepted	<input type="text"/>	dB (A)	
<small>¹⁾ standard unit Liquid Q = m³/h; Steam W = Kg/h; Gas Q_N = Nm³/h</small>			
Valve features			
<input type="checkbox"/> Control valve type	<input type="checkbox"/> Globe	<input type="checkbox"/> Angle seat	<input type="checkbox"/> Diaphragm
	<input type="checkbox"/> Ball valve	<input type="checkbox"/> Butterfly	<input type="checkbox"/> Other
<input type="checkbox"/> Body material	<input type="checkbox"/> Stainless Steel	<input type="checkbox"/> PVC	<input type="checkbox"/> PP
	<input type="checkbox"/> PTFE	<input type="checkbox"/> Other	
<input type="checkbox"/> Surface finish ²⁾	<input type="text"/> internal		<input type="text"/> external
<input type="checkbox"/> Seat sealing material	<input type="checkbox"/> Metal	<input type="checkbox"/> PTFE	<input type="checkbox"/> EPDM ²⁾
	<input type="checkbox"/> FKM ²⁾		
<input type="checkbox"/> Nominal pressure	PN <input type="text"/>		
<input type="checkbox"/> Nominal size	DN <input type="text"/>		
<input type="checkbox"/> Type of connection	<input type="checkbox"/> Flange	<input type="checkbox"/> Socket union	<input type="checkbox"/> Welded
	<input type="checkbox"/> Int. thread	<input type="checkbox"/> Ext. thread	<input type="checkbox"/> Tri-Clamp [®]
<input type="checkbox"/> Standard connection	<input type="checkbox"/> ISO	<input type="checkbox"/> DIN	<input type="checkbox"/> ANSI
	<input type="checkbox"/> JIS	<input type="checkbox"/> Other	
<input type="checkbox"/> Function	<input type="checkbox"/> NC	<input type="checkbox"/> NO	<input type="checkbox"/> Double-acting
<input type="checkbox"/> Pilot pressure	<input type="text"/> min.	<input type="text"/> max.	
<small>²⁾ Only diaphragm valve</small>			
Positioner / Controller			
<input type="checkbox"/> Type 1067 - 3 wire	<input type="checkbox"/> Type 8630 - 3 wire	<input type="checkbox"/> Type 8635 - 2 wire	
<input type="checkbox"/> Valve mounted	<input type="checkbox"/> Remote version		
Power supply 24 VDC	Power supply 24 VDC	Power supply 24 VDC via setpoint or BUS	
Communication	Communication	Communication	
Setpoint/ output analog signal	Setpoint/ output analog signal	Setpoint/ output analog signal	
	or via BUS <input type="checkbox"/> Profibus DP	or via BUS <input type="checkbox"/> Profibus PA	
	<input type="checkbox"/> Device Net	<input type="checkbox"/> Hart	
<input type="checkbox"/> Positioner version	<input type="checkbox"/> Positioner version	<input type="checkbox"/> Positioner version	
Input 0/4 - 20 mA / 0-10 V	Input 0/4 - 20 mA / 0 - 5/10 V	Input 4 - 20 mA	
Output <input type="checkbox"/> 4 - 20mA	Output <input type="checkbox"/> 4 - 20mA	Output <input type="checkbox"/> 4 - 20mA	
or	or/and	or/and	
<input type="checkbox"/> Binary	<input type="checkbox"/> Binary	<input type="checkbox"/> Binary	
<input type="checkbox"/> PID Controller version ³⁾	<input type="checkbox"/> PID Controller version ³⁾	<input type="checkbox"/> PID Controller version ³⁾	
Input measuring signal 4 - 20 mA	Input measuring signal	Input measuring signal	
	4 - 20 mA / Pt100 / Frequency	4 - 20 mA / Pt100 / Frequency	
<small>³⁾ same setpoint for Input and Output signal as for Positioner version</small>			

Please do not forget to fill in the customer data below

Company	Contact person
Customer No	Department
Address	Tel./Fax
Postcode/Town	E-mail

In case of special application conditions, please consult for advice.

We reserve the right to make technical changes without notice.

0602/4_US-en